

# ECOPHON HYGIENE ADVANCE™ A C4

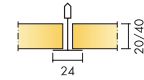

Ecophon Hygiene Advance A C4 is a unique wall to wall, sound absorbing ceiling system for use in demanding environments. All the suspension components, made of acid-proof stainless steel, can endure daily wet cleaning with strong detergents and disinfectants. Examples of applications: areas with constantly high humidity and risk for corrosion; dish rooms and fish industry.

The system consists of Ecophon Hygiene Advance A tiles, which have a core of high density glass wool fully encapsulated in a smooth high-performance film that is impervious to particles and water. The film is also dirt-repellent and resistant to most chemicals. The supporting structure is an exposed Connect T24 C4 grid made of acid-proof high-performance austenitic stainless steel to avoid stress corrosion that can occur on ordinary stainless steel. The weight of the system is 3-4 kg/m<sup>2</sup>. The tiles should be secured to the grid with Connect Hygiene clips in order to withstand pressure during cleaning and to minimise dirt traps. For access to the plenum a special Connect Democlip is used together with a Ecophon Hygiene Advance A tile in 20 mm thickness.

The Ecophon Hygiene Advance A C4 is a technical ceiling system which might have aesthetic variations that will not affect

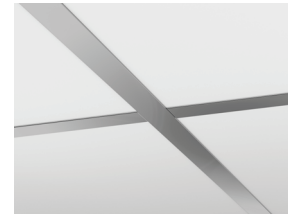

Hygiene Advance A C4 system



Hygiene Advance A C4 section with Connect Hygiene clip 20

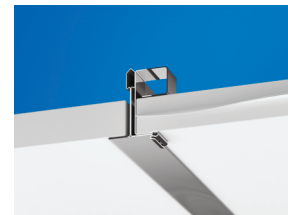

Hygiene Advance A C4 with Connect Demo clip 20 C4

## SYSTEM RANGE

Size, mm	600	1200
	x	x
	600	600
T24	•	•
Thickness	40	40
Inst. Diagr.	M246	M246

## TECHNICAL PROPERTIES

**ACOUSTIC** Sound Absorption Test results according to EN ISO 354. Classification according to EN ISO 11654.

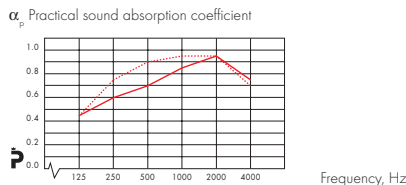

— Ecophon Hygiene Advance A C4, 20mm, 200 mm o.d.s.  
 ..... Ecophon Hygiene Advance A C4, 40mm, 200 mm o.d.s.  
 o.d.s.= overall depth of system

Product	Hygiene Advance A C4, 20 mm thick		Hygiene Advance A C4, 40 mm thick	
o.d.s. mm	200	400	200	400
absorption class	B		A	
NRC	0,80	0,80	0,75	0,75
SAA	0,76	0,79	0,76	0,76

$\alpha_w$  Sound Insulation Not applicable.

Sound Privacy Not applicable

**ACCESSIBILITY** The tiles are demountable. Minimum demounting depth according to installation diagram. The tiles are secured using Connect Hygiene Clip to allow for effective cleaning. The clips are easily removable from above the ceiling. Connect Democlips 20 C4 are available to simplify access to the ceiling void.

**CLEANABILITY** Daily dusting, vacuum cleaning, wet cleaning, high-pressure washing and steam cleaning. Water temperature max. 70°C. Can withstand the use of most disinfecting chemicals.

**VISUAL APPEARANCE** White 141, nearest NCS colour sample S 1000-N, 73% light reflectance. Please note: There is a small difference in gloss between the Hygiene Advance tile and the Hygiene Advance perimeter tile.

**INFLUENCE OF CLIMATE** The tiles withstand a permanent ambient RH up to 95% at 30°C without sagging, warping or delaminating (ISO 4611). A higher temperature/moisture is permissible during washing as stated above. The grid and accessories meet the demands of corrosion class C4 according to EN ISO 12944-2. For the microbiological resistance see Functional demands, Influence of climate.

**INDOOR CLIMATE** Can be used in rooms classified as ISO class 4 according to ISO 14644-1.

**FIRE SAFETY** The glass wool core of the tiles is tested and classified as non-combustible according to EN ISO 1182. See Functional demands, Fire safety.

Reaction-to-fire classification

Country	Standard	Class
Europe	EN 13501-1	A2-s1,d0

**MECHANICAL PROPERTIES** For information regarding live load and requirements for load bearing capacity, see installation diagrams. Conditions: See Functional demands, Mechanical properties.

**INSTALLATION** Installed according to system range. Cut tiles must be sealed with Connect Hygiene Advance Tape. Penetrations must be sealed with a suitable sealant.

## INSTALLATION DIAGRAM (M246) FOR ECOPHON HYGIENE ADVANCE A C4

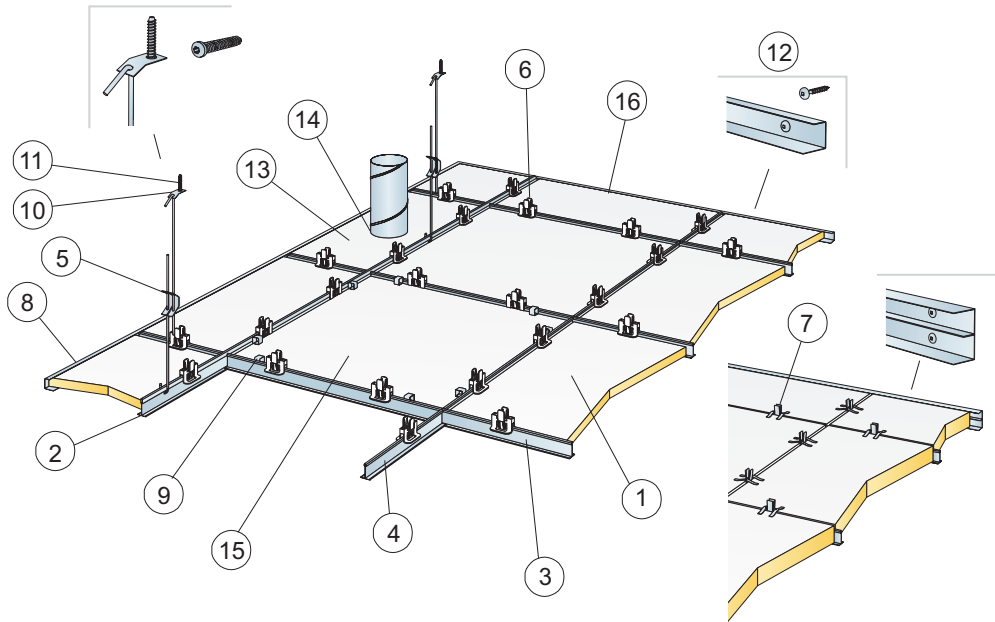

© Ecophon Group

### QUANTITY SPECIFICATION (EXCL. WASTAGE)

	Size, mm	
	600x600	1200x600
1 Ecophon Hygiene Advance A	2,8/m <sup>2</sup>	1,4/m <sup>2</sup>
2 Connect T24 Main runner C4, c1200	0,9m/m <sup>2</sup>	0,9m/m <sup>2</sup>
3 Connect T24 Cross tee C4, L=1200, c600	1,7m/m <sup>2</sup>	1,7m/m <sup>2</sup>
4 Connect T24 Cross tee C4, L=600	0,9m/m <sup>2</sup>	-
5 Connect Adjustable hanger C4, c1200, (max 600 mm distance from wall)	0,7/m <sup>2</sup>	0,7/m <sup>2</sup>
6 Connect Hygiene clip 20 C4	11/m <sup>2</sup>	7/m <sup>2</sup>
7 Connect Hygiene clip 40 C4	11/m <sup>2</sup>	7/m <sup>2</sup>
8 Connect Channel trim C4, fixed at c300 mm	as required	as required
9 Connect Demo clips 20 C4, (where access is needed)	as required	as required
10 Connect Fixing plate C4	0,7/m <sup>2</sup>	0,7/m <sup>2</sup>
11 Connect Anchor screw C4	0,7/m <sup>2</sup>	0,7/m <sup>2</sup>
12 Connect Installation screw C4	3,4/lm Channel trim C4	
13 Ecophon Hygiene Advance technical tile (thickness 20 mm)	as required	as required
14 Joint sealant (not supplied by Ecophon)	as required	as required
15 Ecophon Hygiene Advance A 20 mm (where access is needed)	as required	as required
16 Connect Hygiene Advance Tape	as required	as required

Δ Min. overall depth of system: 150 mm

δ Min. demounting depth: 150 mm

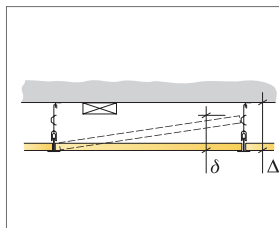

See Quantity specification

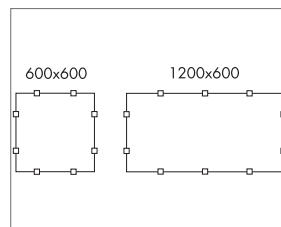

Arrangement of clips

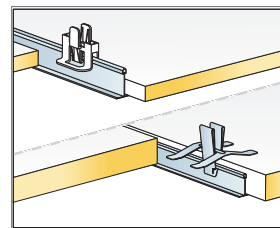

Clips for keeping tiles in place

Size, mm	Max live load [N]	Min load bearing capacity [N]
600x600	40	160
1200x600	40	160

Live load/load bearing capacity